

KENWOOD

AC VOLTMETER

VT-171

VT-171E

INSTRUCTION MANUAL

KENWOOD CORPORATION

© PRINTED IN JAPAN

CONTENTS

1. GENERAL	3
2. FEATURES	3
3. SPECIFICATIONS	4
4. FUNCTIONAL CONTROLS	7
5. OPERATION	8
6. APPLICATIONS	10
7. MAINTENANCE	12
8. ALIGNMENT	13
9. CAUTIONS FOR USE	14

A product of
KENWOOD CORPORATION

2-5, 1-chome Shibuya, Shibuya-ku, Tokyo 150, Japan

1. GENERAL

Your KENWOOD'S Electronic Voltmeter, Model VT-171, [VT-171E], is a voltmeter of absolute-mean value indication type capable of measuring AC voltages from 1mV [300 μ V] to 300V [100V] in the frequency range as wide as 5Hz to 1MHz on root-mean-square value scales. Your VT-171 [VT-171E] is available in variety of applications as it is highly sensitive and responds accurately to given voltages in such a wide frequency range. For use on production lines, it can be controlled by a remote control device(option).

This manual covers two models, the VT-171 and VT-171E.

Most descriptions are common to both models. Where there are differences, the descriptions for the VT-171E are shown enclosed by [].

2. FEATURES

- a. Dual power differential input amplifiers used in the entire circuit provide a high reliability and good characteristic of restoration from possible saturation due to excessive inputs.
- b. A large-sized Taut-band meter has a high sensitivity and reliability.
- c. The number of adjusting trimmers are minimized with the use of the amplifiers which are precisely calculated in the open loop gains and are negative-biased through metal-film resistors as accurate as 1%. The amplifier characteristics, therefore, are free from any secular change.
- d. The input resistance is as high as 10M Ω in all ranges and its parallel capacitance is 45pF or lower.
- e. The meter scales are graduated in the root-mean-square values for sinusoidal waves. Also, the meter has a dB and dBm scales convenient for measuring relative values.
- f. The output terminal allows your VT-171 [VT-171E] to use as a high-gain, wide-band amplifier.

- g. The input attenuators are switched by a so-called "logic control circuit" so that a desired range can be selected with use of a remote control device (option).
- h. A relay and FET switch for range selection, controlled by the logic control circuit, provide higher reliability than usual rotary switch direct switching.

3. SPECIFICATIONS

[Meter Section]

Messurable voltages :	1mV–300mV in 12ranges:1mV, 3mV, 10mV, 30mV,100mV, 300mV,1V, 3V, 10V, 30V, 100V, and 300V full scales. ┌0.3mV–100mV in 12ranges: 0.3mV, 1mV, 3mV, 10mV,30mV, 100mV, 300mV,1V, 3V, 10V,30V, and 100V full scales.┐
dB :	–80~+50dB ┌–90~+40dB┐ (0dB=1V)
dBm :	–80~+52dBm ┌–90~+42dBm┐ (0dBm=1mW, 600Ω)
Error :	Within± 3% of full scale at 1kHz.
Frequency response :	± 10% at 5Hz–1MHz, ± 5% at 10Hz–500kHz and ± 2% at 20Hz–100kHz as referenced to 1kHz response.
Input impedance :	10MΩ ± 5%, with less than 45pF parallel capacitance.
Durable input voltage :	500V(DC+ACpeak) 1V to 300V ┌100V┐ range 100V(DC+ACpeak) 1mV ┌0.3mV┐ to 300mV range

Stability : Within $\pm 0.5\%$ of full scale for $\pm 10\%$ line voltage fluctuation.

Residual voltage : Less than $20\mu\text{V}$ 「 $30\mu\text{V}$ 」 with input shorted on 1mV 「 0.3mV 」 range.

[Amplifier Section]

Gain : $60\text{dB} \pm 1\text{dB}$ 「Approx. 70dB 」

Output voltage : $1\text{V}_{\text{rms}} \pm 20\%$

Output resistance : $600\Omega \pm 20\%$

Frequency response : Within $\pm 3\text{dB}$ at 5Hz – 500kHz .

Distortion : Less than 1% at full scale.
(Rated by signal-noise ratio in 1mV and 1V ranges.)
「(Rated by signal-noise ratio in 0.3mV , 1mV and 1V ranges.)」

Signal-to-noise ratio : Over 40dB at full scale.
「Over 30dB at 0.3mV range」

[Environmental]

Temperature coefficient : $\pm 0.08\%/^{\circ}\text{C}$.

Within specifications temperature : $10\sim 40^{\circ}\text{C}$

Full operating temperature : $0\sim 50^{\circ}\text{C}$

Relative humidity : Less than 80%

[Power Supply Section]

Line voltage : $100, 120, 220\text{V AC} \pm 10\%$,
 $216\text{--}250\text{V AC}, 50/60\text{Hz}$

power consumption : Approx. 4W .

[Dimensions]

$128(130)\text{W} \times 190(215)\text{H} \times 238(260)\text{Dmm}$.
Valuen in () include protrusions.

[Net weight]

2.9kg

[Accessories]

power cable : 1 pc.

Input cable : CA-41, 1 pc.

Replacement fuse : 0.1A 2 pcs. 0.2A 2 pcs.

Instruction manual : 1 copy.

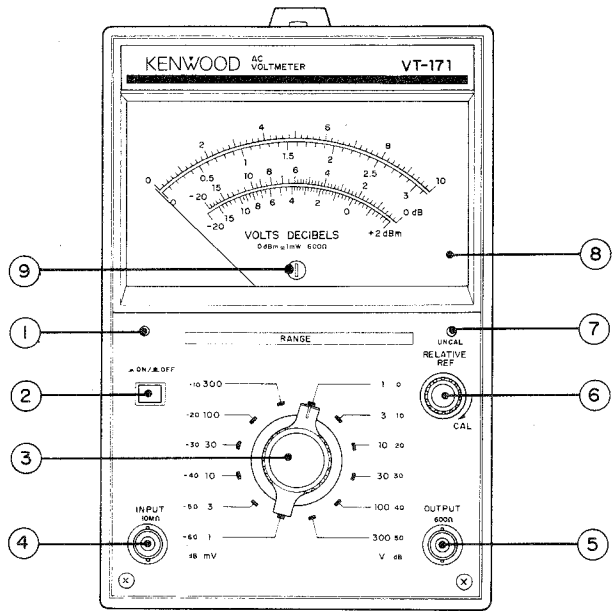

Figure 1—Front Panel View.

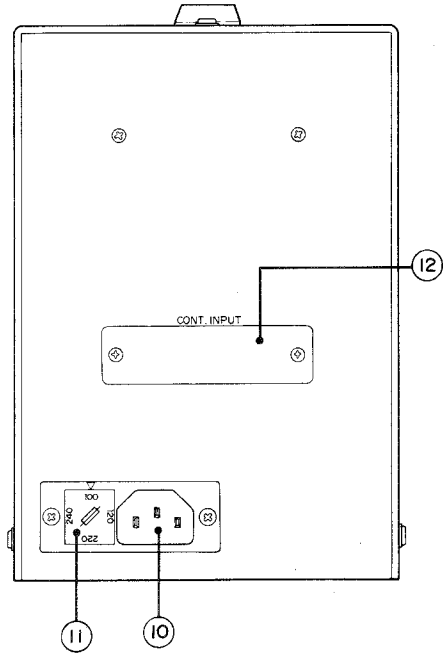

Figure 2—Rear Panel View.

4. FUNCTIONAL CONTROLS

1) Front Panel (see Figure 1)

1. Power-on indicator
2. POWER : ON/OFF switch
3. RANGE : Measurable voltage range selector switch
4. INPUT, 10M Ω : Input connector, 10M Ω impedance
5. OUTPUT, 600 Ω : Output connector, 600 Ω impedance
6. RELATIVE REF : Relative reference control
7. UNCAL : Uncalibration indicator
8. Meter
9. Meter zero-adjust screw

2) Rear Panel (see Figure 2)

10. Power connector
11. Line voltage selector and fuse holder
12. Remote control connector (option) blind.

3) Preset Controls on Side Panel (see Figure 3)

The following controls, placed on the Main PC board (X65-1370-00), are to be preset on the right-hand side panel.

13. TC101 : First Attenuator preset trimmer capacitor
14. VR 101 : First Attenuator preset variable resistor
15. VR 102 : Meter Amplifier gain preset variable resistor

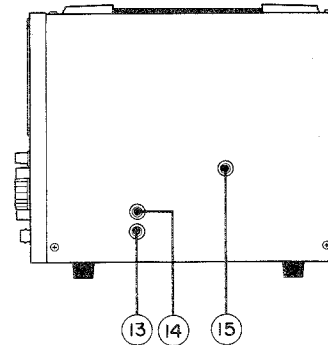

Figure 3 – Preset Controls on Side Panel.

5. OPERATION

• Set-up

1. Press the ON/OFF pushswitch ② in, The Power-on indicator ①, a light-emitting diode, will light, indicating that power has been applied.
2. Plug the measuring cable into the INPUT connector ④.
3. Set the RANGE selector ③ to "300V" [100V]. To measure an AC voltage superimposed on a DC voltage, be sure to set the RANGE selector ③ before connecting the cable to a point to be measured. Otherwise, the DC voltage causes a high surge, which could burn your VT-171 [VT-171E] out.
4. Connect the cable to the point to be measure.
5. Turn the RANGE selector ③ until the Meter pointer swings over one third of the full scale.
6. Read the Meter.

(1) Voltage Scales

There are two black voltage scales: a scale ① graduated 0 to 10 and a scale ② 0 to 3. When the RANGE selector 3 is at "1V", for example, the division 10 on the scale

① indicates 1V. At the "300mV" position, the division 3 on the scale ② indicates 300mV. Similarly, the other RANGE selector positions show their full scale values.

(2) dB Scale

In general, the dB values are expressed in dBV which is a unit referenced by 0 dB equal to 1V. The division 10 at the scale ① corresponds to 0 dB on the dB scale, which is a voltage ratio scale. Since the RANGE selector has 12 range positions in steps of 10dB, the voltage ratio of 1mV [0.3mV] to 300V [100V] is 110dB attenuation. Assume a reference voltage level on the scale ① be 1V with the RANGE selector at "1V", a given voltage can be read as low as -60dB(1mV) [-70dB(0.3mV)] by turning the selector downward. Further, as the scale ① allows reading to -20dB(0.1mV) [-20dB(0.03mV)], you can continuously measure the voltage ratio as high as -80dB(0.1mV to 1V) [-90dB(0.03mV to 1V)]. The read of -80dB [-90dB] means a signal-to-noise ratio of around 20dB [10dB]. Also, the dB scale allows continuous measuring up to +50dB(1 to 300V) [+40dB(1 to 100V)] by turning the selector upward.

(3) dBm Scale

In general, voltmeters have a reference level division of 0dBm equal to 0.775V (1mV power) induced across a 600 Ω resistance load. Therefore, the red dBm scale is available to measure a power level referenced to 0 dBm, with the impedance of the given power circuit being 600 Ω pure resistance. Where measured across specific resistance loads, for example, 10k Ω , other than the 600 Ω load, the levels are sometimes expressed in dBs.

• How to Use Remote Control

Availability of the optional Remote Control is one of outstanding features of your VT-171 [VT-171E].

To attach the Remote Control, remove the blind plate at the rear of your VT-171 [VT-171E]. Install and plug the optional con-necter into the 16-pin connector on the PC board.

The RT-61 option, a remarkable feature of the VT-171, provides a remote control capability. To use the option, remove the case and the rear-panel blind plate, install the connector supplied with the RT-61, then plug the RT-61 into the 16-pin connector on the print circuit board. For details, refer to the RT-61 Instruction Manual.

• How to Use Relative Reference Control

The RELATIVE REF control is kept at "CAL" in general cases of reading calibrated, absolute values on the Meter. To measure relative levels such as frequency responses, turn the control for uncalibration state (UNCAL) until the reference level is set to a desired value, for example, 0dBm. This allows reading the relative levels.

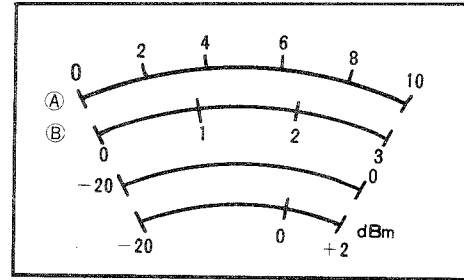

Figure 4— Meter Scale Graduations.

6. APPLICATIONS

The basic use of your VT-171 [VT-171E] is to measure sinusoidal wave voltages as an AC volt meter. In addition, it provides a wide variety of applications as described below.

(1) Amplifier Gain Measurement

Your VT-171 [VT-171E] is capable of measuring an amplifier gain, which is a signal magnification from point A to B in Figure 5 with a signal generator connected to the amplifier input. If the measured signal levels at points A and B are a and b dB, respectively, then the gain is $(b-a)$ dB.

Also, the method is applicable to negative-feedback amplifiers; that is, it is available for measuring an open loop gain of each amplifier circuit with the negative-feedback signal leaves applied.

Further, the method can be used for measuring the frequency responses of given circuits by changing the signal generator frequency.

As an example, let us calculate the open loop gain (from point A to B) of the negative-feedback amplifier shown in Figure 6. Assume that the measured level at

point A be $+1.5$ dB in the -60 dB range and that of point B -4 dB in the $+10$ dB range. The gain from point A to B is

$$(+10\text{dB} - 4\text{dB}) - (-60\text{dB} + 1.5\text{dB}) = 64.5\text{dB}.$$

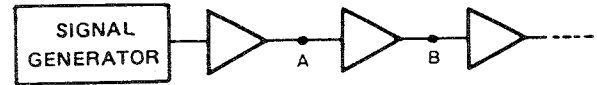

Figure 5— Amplifier Gain Measurement.

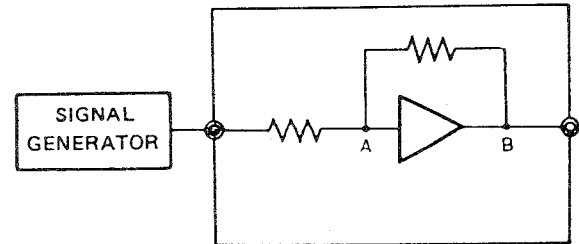

Figure 6— Negative Feedback Amplifier Gain Measurement.

(2) Root-Mean-Square and Peak Value Calculations

Your VT-171 [VT-171E], an voltmeter of absolute-mean value indication type, reads root-mean-square values of sinusoidal wave inputs. Also, it deflects the pointer in proportion to the absolute-mean value of a given input wave.

If the form factor(=root-mean-square value/absolute mean value) of the input wave and the crest(=peak value/root-mean-square value) are known, then the root-mean-square value and peak value can be calculated as follows.

a. Assume that the meter reads V .

- Absolute mean value = $\frac{2\sqrt{2}}{\pi} V \approx 0.9 V$.
- Root-mean-square value = (Absolute mean value) \times (form factor).
- Peak value = (Root-mean-square value) \times (crest).

b. For rectangular waves, their form factor is unity (1) and the crest unit (1).

- Absolute mean value = $\frac{2\sqrt{2}}{\pi} V \approx 0.9 V$.
- Peak value = $0.9 V$.

c. For sawtooth waves, their form factor is $2/\sqrt{3}$ and the crest $\sqrt{3}$.

- Absolute mean value = $\frac{2\sqrt{2}}{\pi} V \approx 0.9 V$.

- Root-mean-square value =

$$\frac{2\sqrt{2}}{\pi} \times \frac{2}{\sqrt{3}} V = \frac{4\sqrt{2}}{\pi\sqrt{3}} V \approx 1.04 V.$$

- Peak value = $\frac{4\sqrt{2}}{\pi\sqrt{3}} \times \sqrt{3} V = \frac{4\sqrt{2}}{\pi} V \approx 1.8 V$.

7. MAINTENANCE

(1) Removing the casing (see Figure 7)

1. Remove the six screws holding the casing on the both sides and top using a Phillips screw driver.
2. Widen the bottom of the 7-shaped casing a little and pull it up for removal.

(2) Mounting the casing (see Figure 8)

1. Widen the bottom of the casing a little when covering it over the main body.
2. Fit the casing PC board retainer to the PC board retainer.
3. Alternately tighten the six screws for uniform torque.

(3) Replacing the fuse (see Figure 9)

REPLACING FUSE

When a fuse goes out, the device is no longer operable. If gone out, check for a trouble cause, remedy it, remove the cap of the fuse holder on the rear panel using a minus screw driver and take it out and replace the fuse with a new one.

When replacing fuse, be sure to check the capacity of a

new fuse for a specified value as follows :

AC 100V, 120 : 0,2A

AC 220V, 240V : 0.1A

CHANGEOVER OF VOLTAGE IN SWITCHING REGULATOR

Remove the fuse holder on the rear side device set, using a minus screw driver, adjust your preferred voltage indication with ▼ mark and plug the holder in. For changing 100V or 120V to 220V or 240V, change the fuse of 0.2A to that of 0.1A.

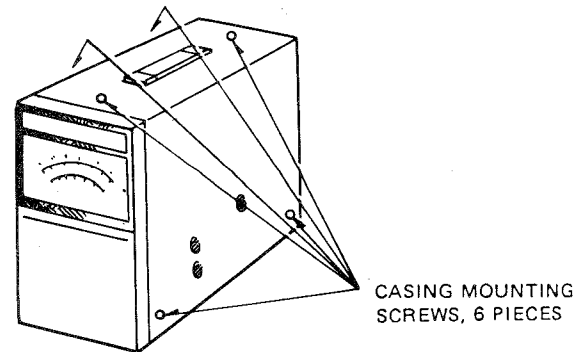

Figure 7- Casing Removal.

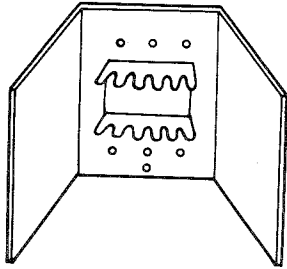

Figure 8— PC Board Retainer.

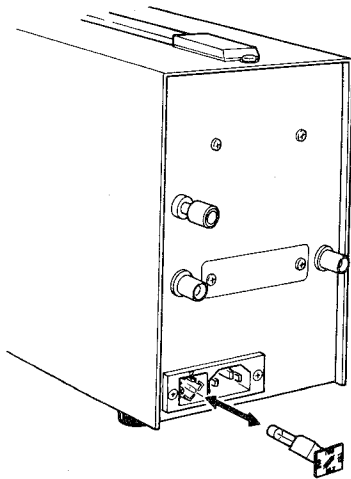

Figure 9— Replacing the e.

8. ALIGNMENT

Your VT-171 was precisely preset at the factory. However, it can be aligned through the adjust holes located on the right-hand side with leaving it housed in the casing, if required. In realignment, first adjust the line voltage to the voltage, use a precisely calibrated measuring instruments, and proceed as follows (also, see Figures 1 through 3).

1. Before turning the ON/OFF switch "ON", adjust the Meter zero-adjust screw until the pointer correctly indicates "0".
2. Connect a voltmeter calibrator 1kHz (or 400Hz) output to the INPUT connector ④.
3. Set the voltmeter calibrator output voltage to 30mV and set the RANGE selector ③ on your VT-171 [VT-171E] to the "30mV" range.
4. Adjust VR102 until the pointer swings to the full scale.
5. In turn, set the voltmeter calibrator output voltage to 10V and set the RANGE selector 3 to the "10V" range.
6. Adjust VR101 until the pointer swings to the full scale.
7. Disconnect the voltmeter calibrator and connect a

wide-band signal generator to the INPUT connector④.

8. Set the signal generator frequency to 1kHz and set the RANGE selector ③ on your VT-171 [VT-171E] to the "1V" range.
9. Adjust the signal generator output voltage until the pointer swings to the full scale.
10. Change the signal generator frequency from 1kHz to 50kHz.
11. Adjust TC101 until the pointer swings to the full scale.
12. Repeat Steps 2 through 11.

9. CAUTIONS FOR USE

1. Your VT-171 [VT-171E] will work just when the POWER switch is pressed in. For accurate measurements, wait around five minutes for warm-up.
2. Avoid placing your VT-171 [VT-171E] where magnetic field and electric field are too strong.
3. The input cable other than the supplied one should be low-capacitance shielded cord, or coaxial cable.
4. The continuous maximum input voltage allowable for your VT-171 [VT-171E] is 100V (DC+AC peak) with the RANGE selector at "-60dB [-70dB]" to "-10dB [-10dB]". Full care should be observed in measuring high voltages.
5. Be careful of a line noise and similar small noises as your VT-171 [VT-171E] is a highly sensitive voltmeter.
6. Do not leave your VT-171 [VT-171E] at any of high temperature and humidity places for a long period of time.
7. The ON/OFF switch of this is designed to act on the secondary side of the power transformer. The primary side of the transformer remains energized even if the ON/OFF switch is set to OFF. Therefore, if the unit is to be unused for a long time, the power cord should be unplugged in the receptacle outlet.